



# DATA SHEET

## Hall Effect Current Sensor

**PN: CHB\_LTHB15D**

**IPN=350~500A**

### Feature

- Closed- loop (compensated) current transducer
- Capable measurement of currents: DC, AC, pulse with galvanic isolation between primary circuit and secondary circuit.
- Supply voltage: DC  $\pm 15 \sim \pm 24V$

### Advantages

- High accuracy
- Easy installation
- Low temperature drift
- Optimized response time
- High immunity to external interference
- Very good linearity
- Can be customized

### Applications

- Variable speed drives
- Welding machine
- Battery supplied applications
- Uninterruptible Power Supplies (UPS)
- Electrochemical

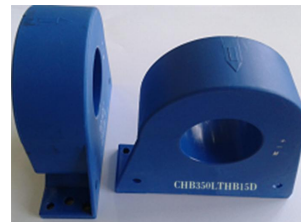

**RoHS**

**Electrical data**     $T_a=25^\circ C$      $V_c= \pm 15VDC$

Parmeter \ Ref	CHB350 LTHB15D	CHB400 LTHB15D	CHB500 LTHB15D
Rated input $I_{pn}(A)$	350	400	500
Measuring range $I_p(A)$	1200 ( $\pm 24V, 17\Omega$ )	1200 ( $\pm 24V, 36\Omega$ )	1500 ( $\pm 24V, 24\Omega$ )
Turns ratio $N_p/N_S (T)$	1:2000	1:4000	1:5000
Output current rms $I_S(mA)$	175 $\pm 0.2\%$	100 $\pm 0.2\%$	100 $\pm 0.2\%$
Secondary coil resistance $R_S (\Omega)$	15	40	50
Measure resister with $\pm 15V$ RM ( $\Omega$ )	@ $\pm 500A_{max}$ 30(max)	@ $\pm 400A_{max}$ 100(max)	@ $\pm 500A_{max}$ 91(max)
	@ $\pm 900A_{max}$ 8(max)	@ $\pm 800A_{max}$ 30(max)	@ $\pm 1000A_{max}$ 20(max)
Measure resister with $\pm 18V$ RM ( $\Omega$ )	@ $\pm 500A_{max}$ 50(max)	@ $\pm 400A_{max}$ 130(max)	@ $\pm 500A_{max}$ 120(max)
	@ $\pm 1200A_{max}$ 10(max)	@ $\pm 800A_{max}$ 43(max)	@ $\pm 1000A_{max}$ 33(max)
Supply voltage $V_C(V)$	$\pm 15 \sim \pm 24$		
Zero offset current(mA)	@ $I_p=0$ $\leq \pm 0.2$		



# Cheemi Technology Co., Ltd

Offset current drift(mA)	@ -40°C ~ 85°C	≤±0.5
Accuracy XG(%)	@IPN,T=25°C	< ±0.1
Linearity error $\epsilon_r$ (%FS)	@ $I_p=0-\pm I_{pn}$	≤0.1
Di/dt accurately followed A/μs		> 100
Response time $t_{ra}$ (μs)	@100A/μS,10%-90%	<1.0
Power consumption $I_C$ (mA)		≤20+ $I_p \times (N_p/N_s)$
Bandwidth BW(KHZ)	@ -3db	DC...100
Insulation voltage $V_d$ (KV)	@ 50HZ,AC,1min	6

## General data

Parameter	Value
Operating temperature $T_A$ (°C)	-40 ~ +85
Storage temperature $T_S$ (°C)	-40 ~ +125
Mass $M$ (g)	290
Plastic material	UL94-V0.
Standards	EN60947-1:2004
	IEC60950-1:2001
	EN50178:1998
	SJ 20790-2000

## Dimensions(mm):

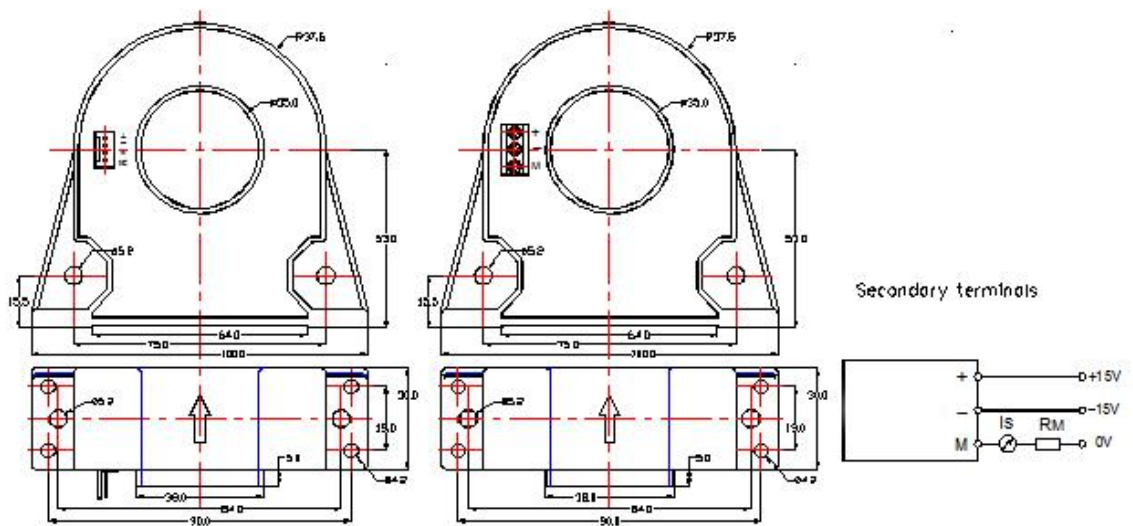

### Remarks:

CHB-LTHB can be divided into two types CHB-LTHB1 and CHB-LTHB2

1. All dimensions are in mm.
2. General tolerance  $\pm 1$ mm
3. CHB-LTHB1: With Molex connector(Molex 22011042: 5045-04AG, 5051-04)
4. CHB-LTHB2: With DG300-5.0 connector



**Characteristics chart:**

Pulse current signal response characteristic

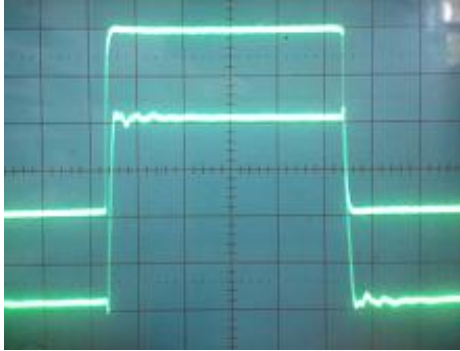

← input signal  
← output signal

Effects of impulse noise

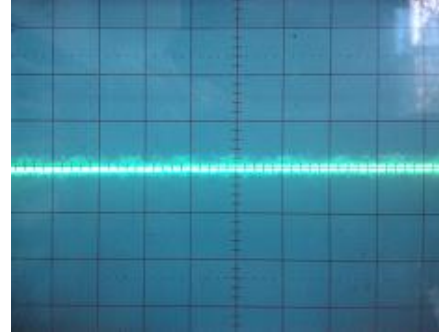

← Output voltage

**Directions for use**

- When the current goes through the primary pin of a sensor, the voltage will be measured at the output end.
- Is will be in a forward direction when the  $I_p$  flows according to the direction of arrowhead.
- Custom design is available for the different rated input current and the output voltage.
- The dynamic performance is the best when the primary hole if fully filled with.
- The primary conductor should be  $\leq 120^\circ\text{C}$ .

**WARNING : Incorrect wiring may cause damage to the sensor.**

